



# **Pipeline Station Pulsation Case Study: Minimal Piping Change Creates Complicated Problems**



**Authors:**

**Noah Dixon, Sr. Technical Specialist, Williams Gas Pipeline**

**Carol Palynchuk, Design Project Manager, Beta Machinery Analysis**

**Shelley Greenfield, Vice President Design Services, Beta Machinery Analysis**

**Presenters:**

**Noah Dixon, Williams Gas Pipeline**

**Shelley Greenfield, Beta Machinery Analysis**

keywords: reciprocating compressor, centrifugal compressor, pulsation, vibration, pipeline station vibration analysis

## 1 ABSTRACT

Williams Gas Pipeline has a large compressor station at Wadley, Alabama with 15 large slow speed integral reciprocating compressors and two centrifugal compressors, feeding multiple pipelines. Recently the surge piping of one of the centrifugal compressors (Unit 16) was changed for process reasons. This relatively small change in piping resulted in high vibration in the common 42 inch discharge header. This resulted in small bore piping failures and high vibrations at the surge control valve and associated piping of the centrifugal compressor.

This paper is a case study about the acoustic resonances in yard piping and headers. It illustrates that small piping changes can generate unintended consequences to the station reliability. The authors will illustrate the field and design issues involved in modifying compressors and piping at pipeline stations.

## 2 BACKGROUND

Williams Gas Pipeline Station 110 is located in Wadley, Alabama. This facility is a natural gas compressor booster station. Currently there are 17 compressors on site; 15 Cooper Bessemer low speed (240 – 250 RPM) integral reciprocating compressors and two centrifugal units, see Table 1 for the list of compressors. Only one of the centrifugal compressors is tied into the piping system with the reciprocating compressors.

**Table 1. Equipment Description**

Unit	Manufacturer	Type	HP	# of Cylinders	Bottle Internals
1	Cooper-Bessemer	GMW-10	2,500	3	Empty Bottle
2	Cooper-Bessemer	GMW-10	2,500	3	Empty Bottle
3	Cooper-Bessemer	GMW-10	2,500	3	Empty Bottle
4	Cooper-Bessemer	GMW-10	2,500	3	Empty Bottle
5	Cooper-Bessemer	GMW-10	2,500	3	Empty Bottle
6	Cooper-Bessemer	GMW-10	2,500	3	Empty Bottle
7	Cooper-Bessemer	GMW-10	2,500	3	Empty Bottle
8	Cooper-Bessemer	GMWA-10	2,625	3	Filters
9	Cooper-Bessemer	GMWA-10	2,625	3	Filters
10	Cooper-Bessemer	GMWC-10	3,400	3	Filters
11	Cooper-Bessemer	GMWC-10	3,400	3	Filters
12	Cooper-Bessemer	GMWC-10	3,400	3	Filters
13	Cooper-Bessemer	10V-250	3,400	3	Filters & Secondary Volumes
14	Cooper-Bessemer	16V-250	5,500	8	Filters & Secondary Volumes
15	Cooper-Bessemer	16V-250	5,500	8	Filters & Secondary Volumes
16	Solar	Mars	15,000	N/A	N/A
17	Solar	Titan	20,500	N/A	N/A

The initial units were installed in 1951 and over the next 59 years the station has gone through a variety of additions and modifications to accommodate growing demand and address unforeseen process issues and vibration problems. A brief history of the station is as follows:

- In March of 1951 Williams installed five reciprocating compressors.
- By October of 1951 Units 6 and 7 were added.
- In 1958 additional compression was required and Units 8 and 9 were brought online.
- Unit 10 was added in 1962.
- Units 11 through 14 were introduced in the 1960s.
- Unit 15 was installed in 1971.
- In 1989 another expansion was implemented and Unit 16 was installed.

- In the late 1990s the horsepower on Unit 16 was updated from 12600 to 15000 HP and it was at this time Unit 16 started having vibration problems. A short piece of pipe was added to the discharge header to reduce vibration levels.
- In 2010 Unit 17, a centrifugal compressor, was added.
- In 2011 piping in the cooler area was modified to accommodate additional gas coolers that were added.
- In 2011 the surge piping on Unit 16 was modified; four surge/bypass valves were removed and replaced with one surge valve, see Figure 1.

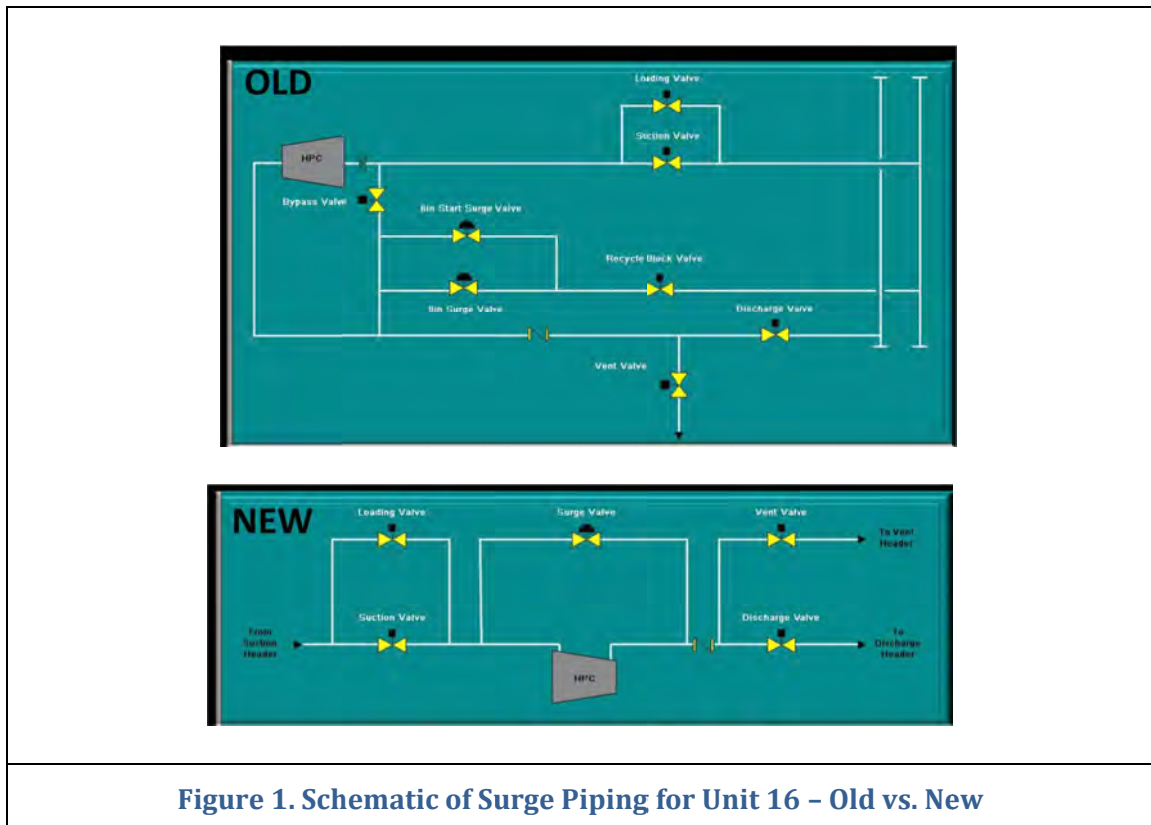

**Figure 1. Schematic of Surge Piping for Unit 16 – Old vs. New**

The 2011 change to the Unit 16 surge piping was the “straw that broke the camel’s back.” The resulting piping failures illustrate how piping changes can create unintended consequences, such as:

- Integrity concerns due to fatigue failure in the piping system
- Safety risks
- Unexpected station downtime

### 3 PULSATION AND VIBRATION CONTROL

#### 3.1 Individual Unit vs. Station Analysis

The units installed in 1951 (Units 1 through 7) were very likely installed without any consideration of pulsation control (given the pulsation bottles are empty volumes as noted in Table 1 and the era – the use of reciprocating compressors in the pipeline industry was fairly new). For the subsequent units some level of acoustical study was performed for individual units, not the entire station, each time a major expansion occurred. Internal filters were used in all pulsation bottles except for Units 1 to 7.

In 1969 and 1971 reciprocating compressor Units 14 and 15 were installed. In 1989 Unit 16, a centrifugal compressor, was also installed in parallel. The ability to perform complex acoustical modeling of the entire station was very limited at the time and not commonplace. As a result there was no acoustic model of the overall compressor station and yard piping. The interaction of the new units and existing units had never been investigated. Up to this time there had been no major pulsation or vibration problems noted at the station.

In the late 1990s the horsepower for Unit 16 was increased. This was the beginning of the vibration problems in the area of Unit 16. In 2011 when the surge piping for the Unit 16 centrifugal compressor was modified, severe vibration problems were identified in the discharge piping:

- High piping vibration was taking place in the header.
- The surge valve operator, as well as other piping, was now showing signs of high vibration.
- The vibration of small bore attachments was bad enough that it was anticipated a failure would occur.
- In December of 2011 a small bore nipple, located on the Unit 14, 15 and 16 common header, failed.



**Figure 2. Unit 16 Surge Valve Operator**

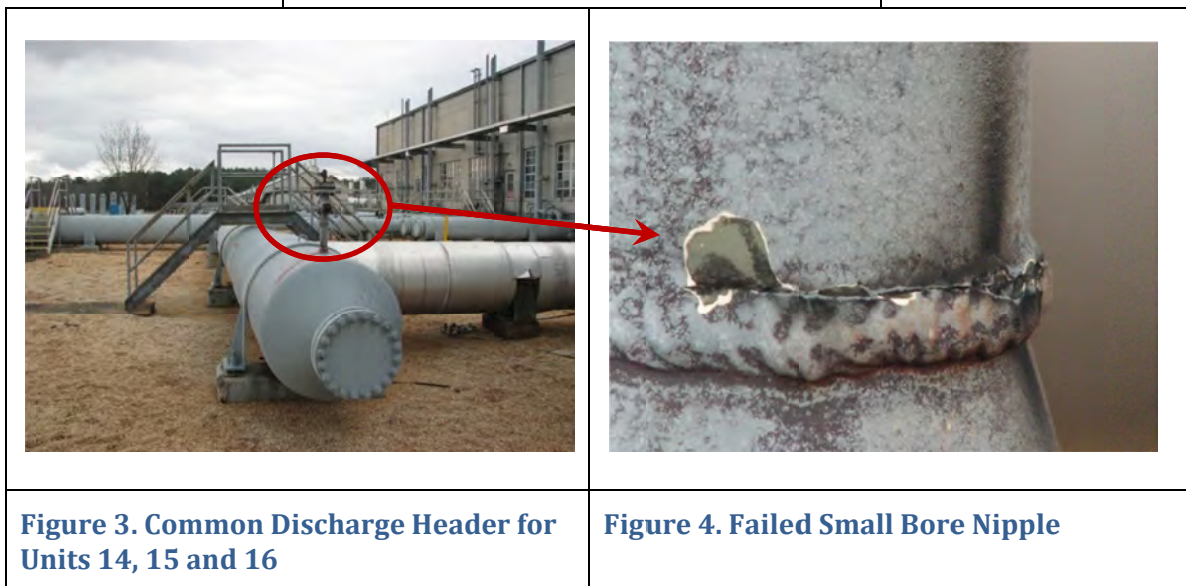

**Figure 3. Common Discharge Header for Units 14, 15 and 16**

**Figure 4. Failed Small Bore Nipple**

Given the escalating vibration issues experienced over the past couple of years Williams decided to call in a vibration consultant to help identify the root cause of the problem and find a solution to the growing vibration problems.

A short visit in August 2011 took place to collect vibration and pulsation data. Tests identified the frequencies contributing to the problem and located the highest vibration (in the header near Unit 16). Vibrations were high at the surge valve even if Units 14, 15 and 16 were not running (Units 14, 15 and 16 share a common discharge header). Finding a quick “band-aid” solution was impossible due to the complex piping system and the pulsation interaction between the 16 units.

The field visit verified that years of additions and changes to the station finally resulted in the need to step back and look at the station design as a whole. It was concluded that an acoustical model of the overall station was required. A computer simulation would allow Williams and the consultant, Beta Machinery Analysis, to test each solution against a variety of different scenarios.

### 3.2 Challenges of Modeling a Complex Station

The 16 compressors that are acoustically tied together can be operated independently creating literally hundreds of potential operating scenarios. There are as many as 24 different load steps for most units, as seen in Figure 5. As well, the interaction of pulsations between compressors, multiple headers and parallel paths to the coolers create many opportunities for acoustical resonance.

An acoustical model of the discharge header system for 16 of the 17 compressors was developed. This was no trivial feat. The model had to be able to accommodate the following:

- Calculate pulsation source for all the different configurations of reciprocating compressors
  - Model multiple load steps per unit
  - Determine operating conditions based on field data, bits and pieces of performance information and control panel screenshots – some important information was missing on old units (vintage 1950s)
- 16 units online and offline at various times
- Large parallel paths in the area of the coolers

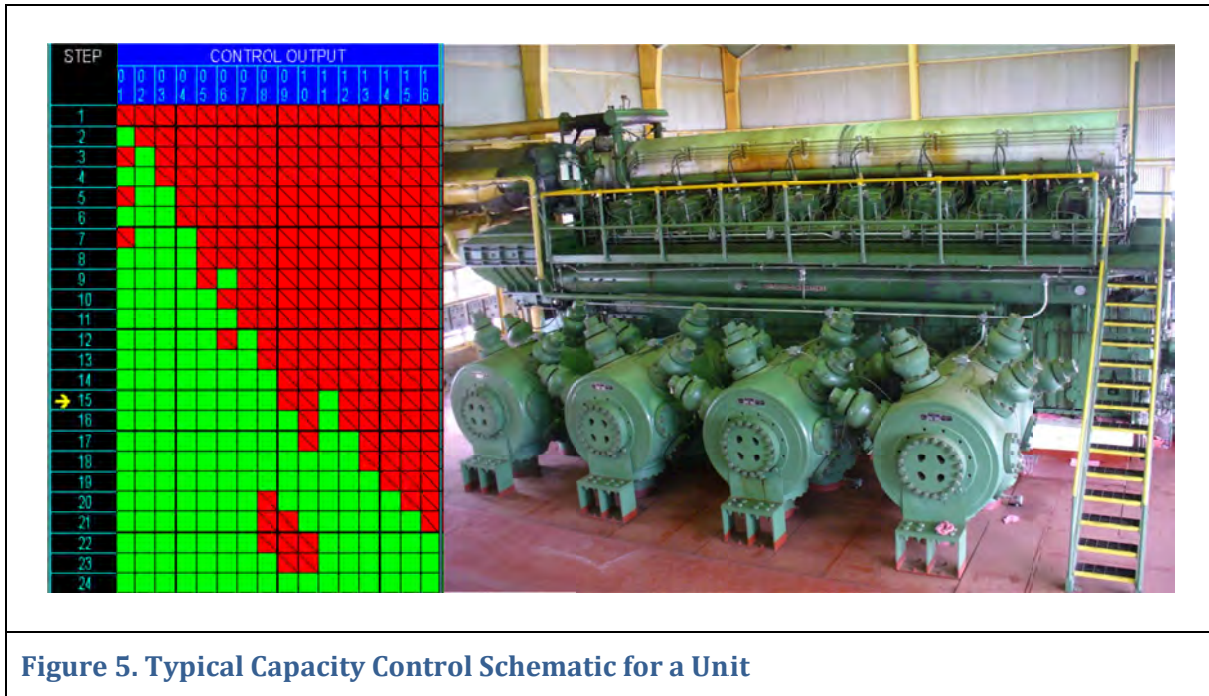
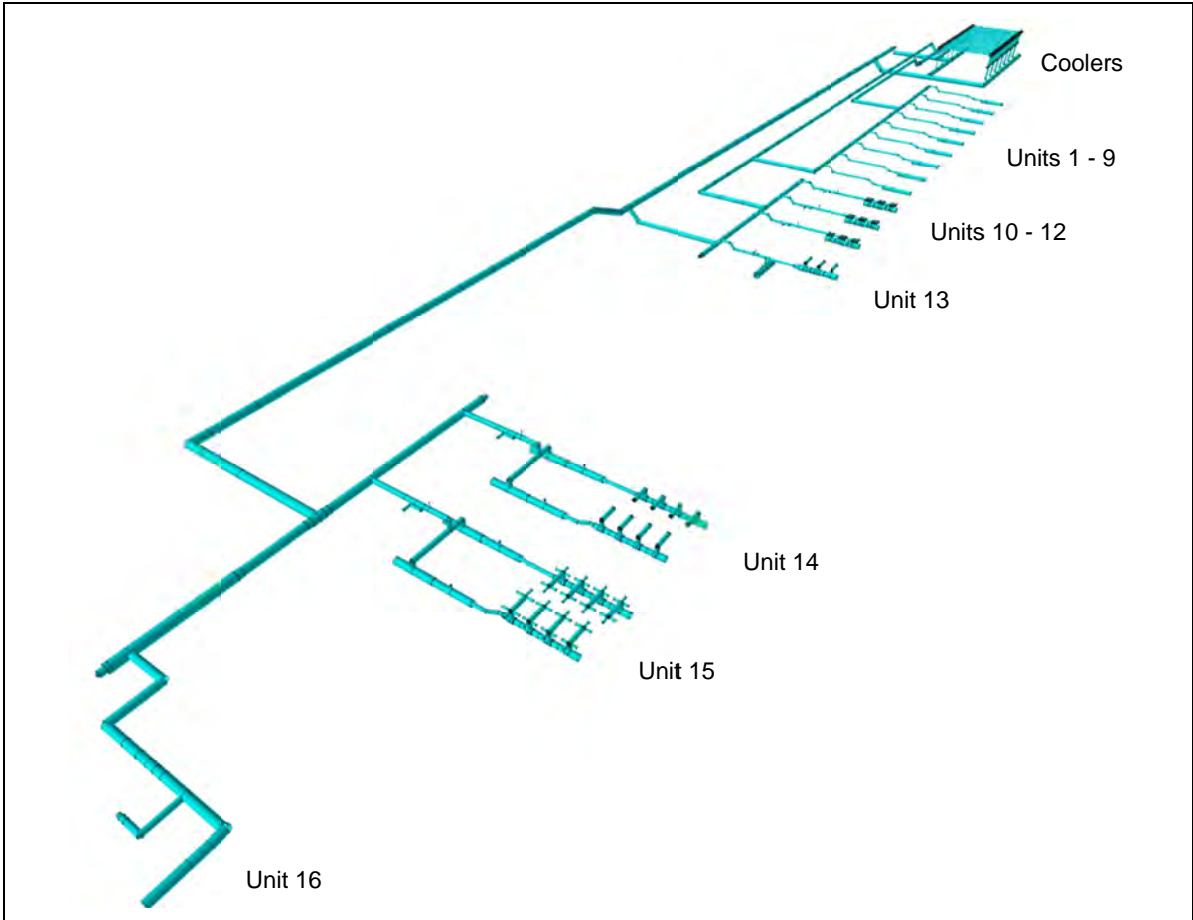

Figure 5. Typical Capacity Control Schematic for a Unit

### 3.3 What was Discovered

Units 14, 15 and 16 share a common header, see Figure 6. Very high forces were predicted in the several spans of piping near Unit 16, as shown in Figure 7.

Really high shaking forces in the Unit 16 centrifugal compressor discharge lateral piping were driving the connected surge piping, see Figures 8 and 9.



**Figure 6. Discharge System Acoustical Model Schematic**

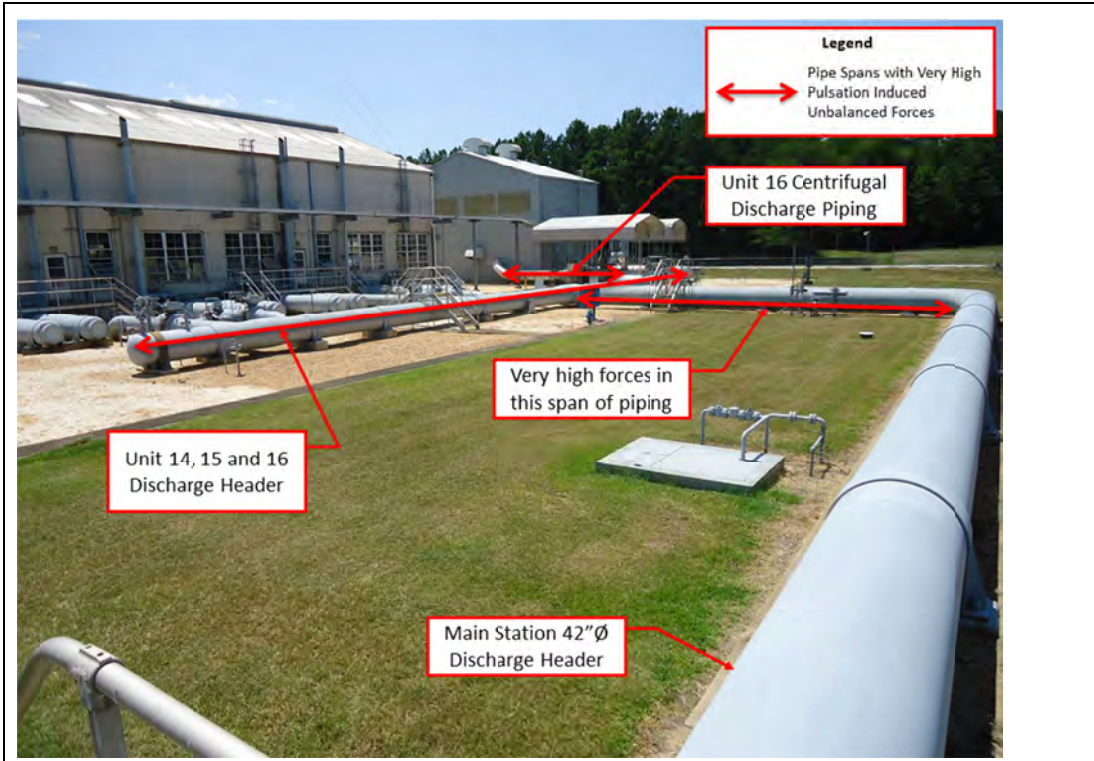

**Figure 7. Pipe Runs with Highest Shaking Forces**

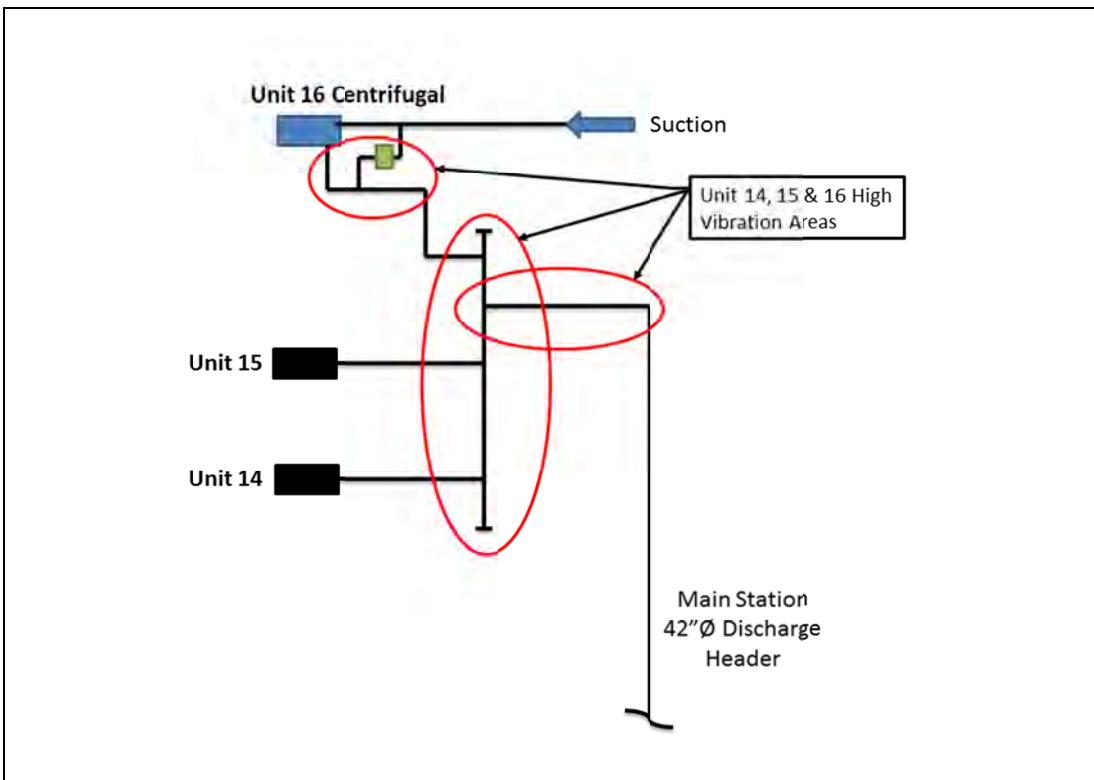

**Figure 8. Unit 16 Schematic**

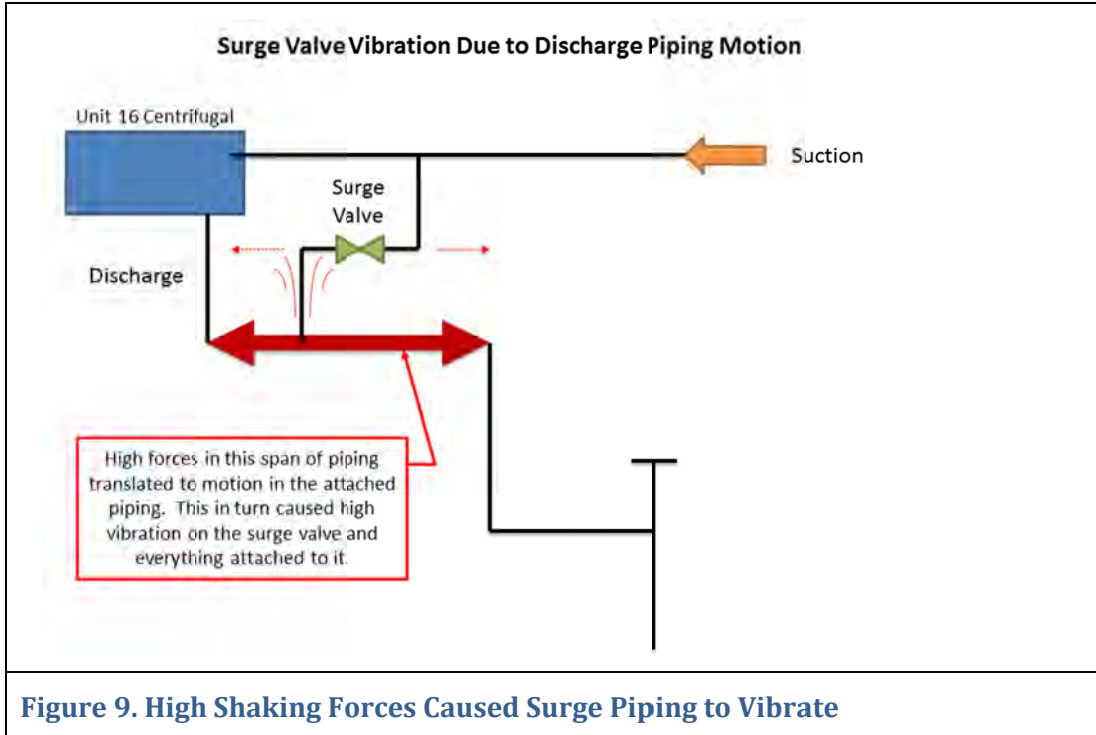

Really high forces in the Unit 14, 15 and 16 common discharge header and pipe connecting the common header to main 42" diameter header caused the small bore failure at the end of the Unit 14, 15 and 16 header, see Figure 10.

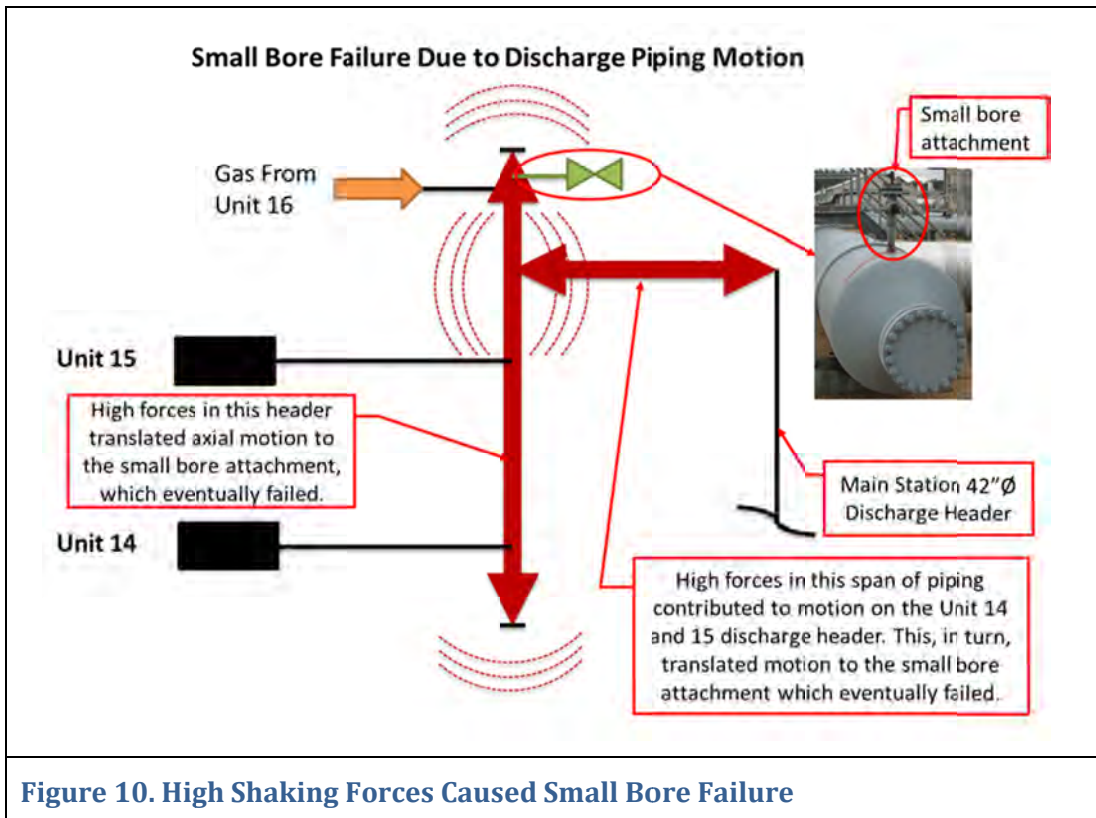



The model also confirmed that the shaking forces, hence the vibration, in a given area varied greatly depending on which unit is considered as a source of pulsation, as well as, how many units are online. Figure 11 summarizes how shaking forces in the existing system change as the number of units online and offline changes. For example:

- Comparing forces in Group 1 to Group 3:
  - Group 1 shows the shaking forces in a few key problem areas around Unit 16 with Units 10 through 16 online and Unit 15 as the source of pulsation.
  - Group 3 is the same acoustical model, except Unit 14 has been taken offline.
  - The shaking forces in the Unit 16 lateral piping and the common header for Units 14, 15 and 16 double in amplitude by having one less unit online.
- Group 6 helped to validate the model against what operators were experiencing in the field. Some of the highest vibration in the area of Unit 16 occurred with Units 14, 15 and 16 were all offline. This operating scenario had the highest shaking forces in the Unit 14, 15 & 16 header.
- Comparing forces in Group 5 to Group 7:
  - Group 5 shows the shaking forces in a few key problem areas around Unit 16 with Units 10 through 16 online, and Unit 13 as the source of pulsation.
  - Group 7 is the same acoustical model, except Unit 15 has been taken offline.
  - In this case, the shaking forces change very little when one less unit is online.

Without the help of a detailed acoustical model it would be next to impossible to understand how the system behaves as units come online and offline.

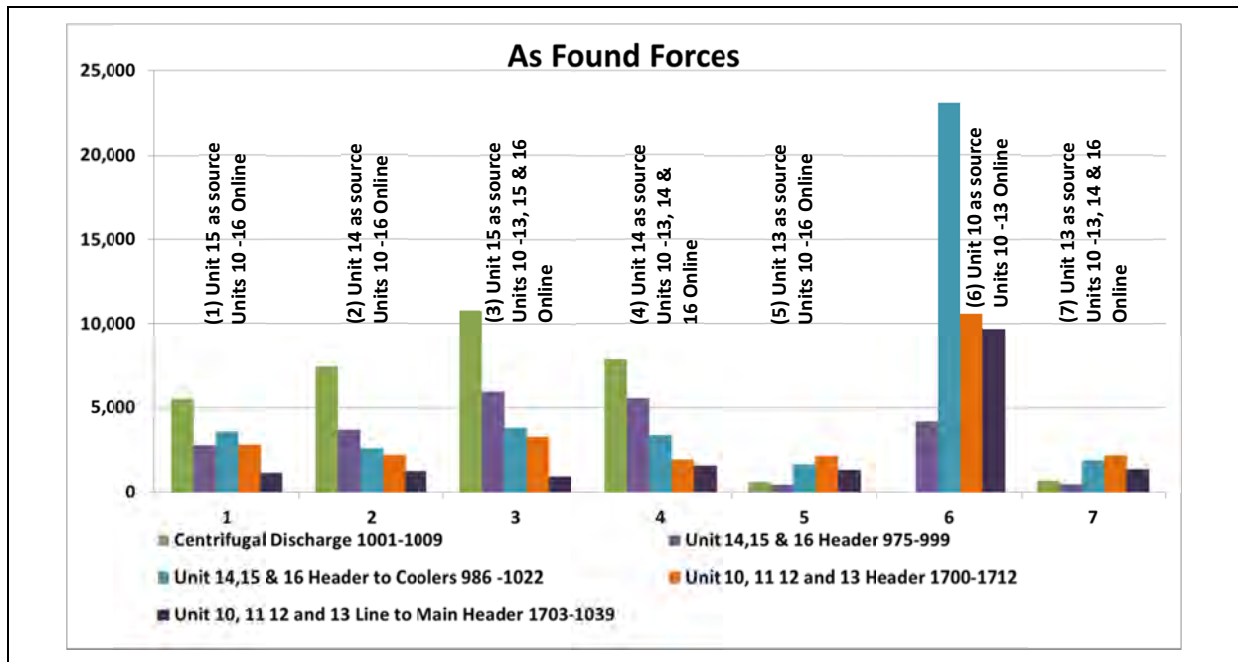
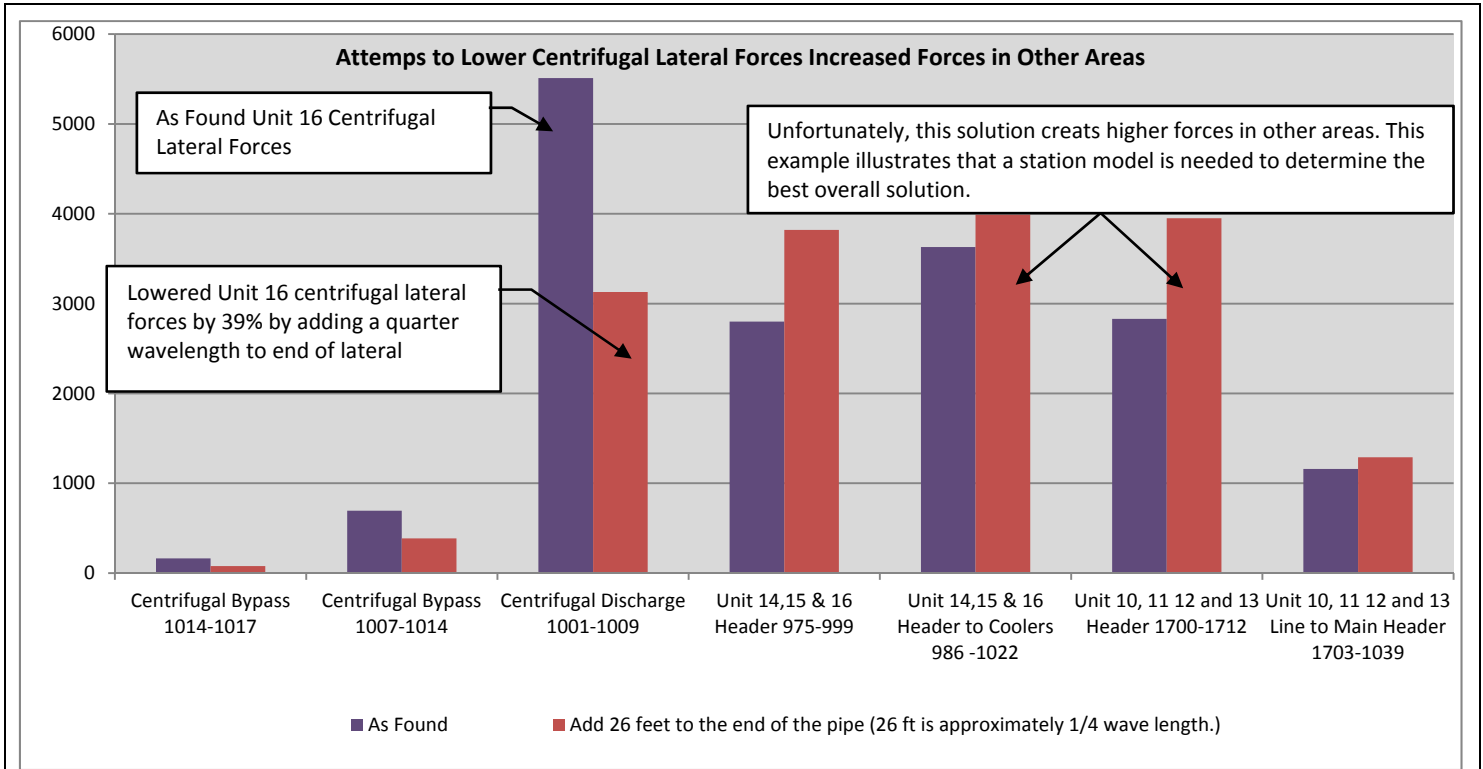

**Figure 11. High Shaking Forces Vary with Units Online**

### 3.4 Solutions to Control Vibration

With a model built and validated and an understanding of the cause of the high vibration and failures in hand, the next step was to investigate modifications to reduce the high shaking forces in the area of Units 14, 15 and 16. Williams, of course, was very concerned about pressure drop. Their main criterion was that the final solution had to introduce minimal pressure drop.

Evaluation using standard pulsation theory ended up at a dead end. Each time a potential solution was identified it reduced forces in one area and created a new problem in another area. As shown in Figure 12, adding a quarter wave resonator off the Unit 16 discharge piping had a big impact in lowering the shaking forces that were exciting the surge valve, but increased some of the forces that resulted in the small bore failure on the Unit 14, 15 and 16 header.



**Figure 12. Attempts to Lower Centrifugal Lateral Forces Increased Forces in Other Areas**

After more than 80 modifications were evaluated, a final solution was found that met the following criteria:

- Reduced forces in the areas of concern
- Avoided consequences in other areas of the plant
- Did not add any significant pressure drop
- Was relatively easy for Williams to implement

Since there is no perfect solution to this complex problem, the design team focused on finding an optimal approach. The final solution involves removing the header for Units 14, 15 and 16 (eliminates some of the problem pipe spans) and discharging units 14, 15 and 16 directly into the 42 inch diameter common header. There will also be some speed limitations for the rare operating case where any two or three of Units 14, 15 & 16 are offline at the same time. Restraint speed on a couple of units was an acceptable solution for the operations team.

The final step in the process is to assess the piping flexibility (thermal analysis). This may require enhancements to piping supports in the affected area. At the time of writing, the study is underway.

## 4 LESSONS LEARNED

Incremental changes to a compressor station can create unintended consequences. In this case, a variety of seemingly minor changes over many years created station-wide reliability issues.

When modifying a compressor station, a station acoustical model would be helpful to point out pulsation forces, pressure drop, and performance impacts with a proposed design (prior to starting construction). Evaluating alternatives is very quick and cost effective, compared to the costs involved in making changes after the system is commissioned.