

Piping Vibration Examples

These examples illustrate various piping vibration problems. Advanced vibration analysis is required to solve these dynamic issues: flow-induced vibration (FIV), acoustic induced vibration (AIV), and other common issues. BETA recommends that piping vibration be assessed during the design stage to avoid costly piping modifications during operations (see Piping Vibration and Integrity Assessment).

1 Hydrogen/Butane Gas Compressors (FIV Example)

This refinery utilizes large centrifugal compressors. The piping system is shown below (left). Vibration problems occurred on the piping header feeding three dryers (right).

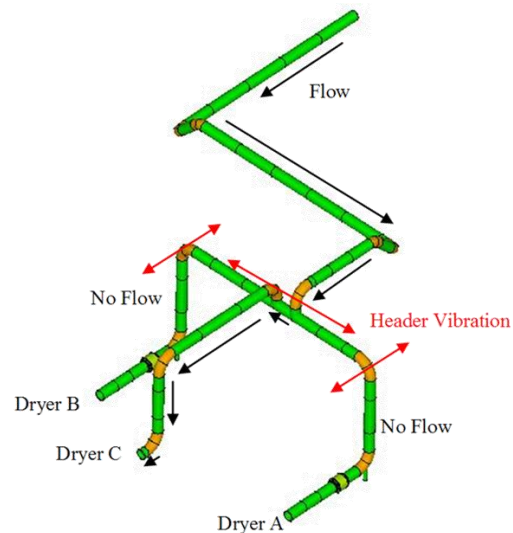

Normally the gas flow travels through two dryers and no vibration issues occur but under regeneration, the operators use only one dryer. When flowing to one dryer, the operator measured high vibrations in the header as shown by the red arrows (above, right).

BETA's field team was hired to analyze and address the problem. While onsite, BETA measured natural frequencies, vibration displacement, pressure pulsations, operating deflection shape, and other parameters. After reviewing the results it was confirmed that the vibration was due to a complex FIV problem. Note that FIV can also be called Eddy Shedding or Vortex Shedding.

One solution was to eliminate flow induced excitations by changing the length of the inlet header and the distance between Dryer A and B inlet valves. This was determined to be too expensive, so BETA designed supports to be installed at specific locations in order to shift the mechanical natural frequency away from resonance.

Evaluating FIV risks during the design stage is recommended for centrifugal compressor systems, and will avoid expensive piping modifications during operations.

2 Turboexpander/Booster Compressor (FIV Example)

For this deep cut gas plant, the process removes ethane and propane from the natural gas stream. To save energy, a turboexpander is used instead of an inefficient, and therefore costly, Joule-Thompson Valve.

BETA was hired to address severe vibration in the overhead suction piping system. The vibrations were so severe that personnel did not want to be present in the building for fear of piping failure. As seen in the pictures below, the piping system is complex with many dead legs.



BETA measured high pulsations in the suction dead legs at 15 Hz, the same frequency as the calculated Strouhal frequency. This confirms the excitation force was due to the 15 Hz pulsations and is an FIV problem.

The standard FIV problem occurs when a quarter wave Acoustical Natural Frequency (ANF) coincides with the excitation frequency (15 Hz pulsations); but in this case, the problem was much more complicated than the standard FIV problem. All of the relevant dead legs were analyzed and it was discovered that none of them matched the 15 Hz frequency (quarter wave ANF).

So what explains the piping resonance and severe vibration?

After reviewing the piping geometry in more detail, BETA discovered that an entire piping section comprising of the header and dead legs had a 15 Hz ANF – something very rarely seen. Once the source of the FIV problem was found, BETA recommended modifications to alleviate the resonance.

This example illustrates that evaluating ANFs can be complicated, requiring specialized acoustical analysis software and analysis techniques. BETA's software tools provide a cost-effective approach to identify and avoid these risks during the design stage.

3 FIV and AIV Analysis for Centrifugal Compressors

BETA was retained to assess piping vibration in a large centrifugal compressor facility used for power generation. Higher vibrations were measured when the compressor's recycle valve was 40% open compared to when it was only 23% open.

The following schematic shows the main piping system including hot and cold recycle. The area of high vibration is shown by the dotted circle. BETA's engineering design team identified many locations where FIV or AIV could be the source of the excitation forces.

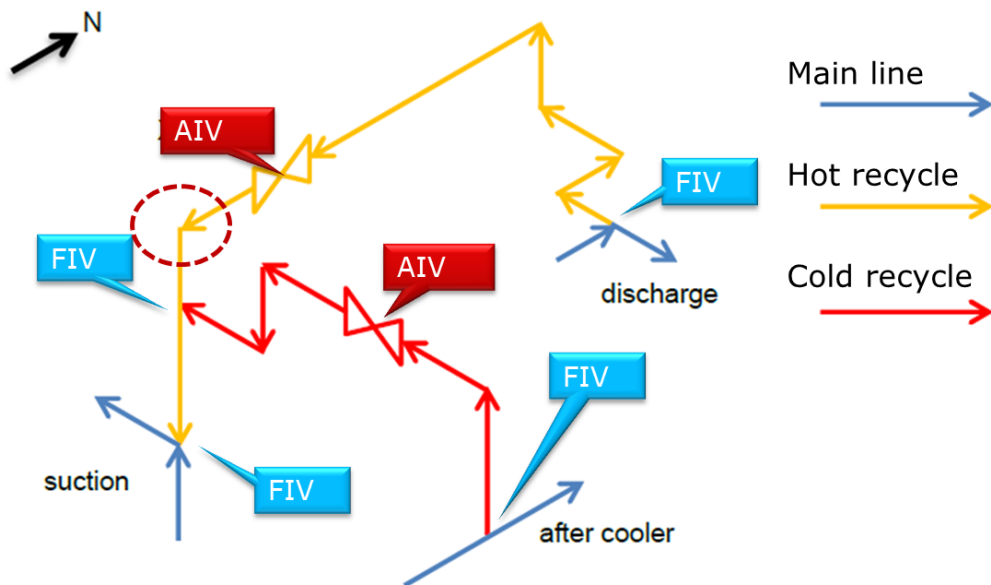

Each of the potential FIV and AIV locations were evaluated in more detail including different operating scenarios (flows, temperatures, etc.). Through this advanced analysis, BETA was able to identify one FIV location and one AIV that likely contributed to the problem.

Recommendations to modify the valve trim will reduce the risk of AIV problems. To reduce FIV problems, certain flow rates should be avoided. This is not always practical, therefore, other solutions were provided. This case illustrates the combination of FIV and AIV risks that affect piping systems.

4 Piping Vibration on Sales Gas Line (Gas Plant Example)

The 30 inch (75 cm) sales gas line had high vibration at this Asian Gas Plant. High vibration became evident on the main sales gas line under high flow / high pressure drop conditions following the installation of a new whisper trim pressure control valve. BETA's staff conducted a site vibration assessment to determine the cause of and possible solutions to piping vibration and integrity concerns.

Based on the field analysis, the vibration upstream of the control valve is caused by Flow Induced Excitation (FIE, also called FIV) which is created when gas flows past a deadleg. The deadleg creates vortices, which are amplified by the standing wave in the deadleg. These pulsations travel through the pipe and cause it to shake.



Three solutions were identified to reduce the excitation forces. These options included: modifications to the operation of the bypass valve; a minor modification at the mouth of the deadleg; or modifying the piping geometry by moving the recycle valve.

Under some flow condition the piping at the expansion loops was observed to exhibit very high vibration. The piping in this area is very loosely supported and any unbalanced force in the piping system will result in high vibration on these lines. If the FIV created by the deadleg near the control valve cannot be controlled, then increasing the stiffness of the expansion loops will help control vibrations. BETA provided recommendations on adding beams to support the elbows. In addition to these piping support recommendations, a pipe stress analysis is required to ensure the additional supports do not create thermal stress problems.

